



TOG EQUIPMENT LEASING, LLC

ASK ABOUT OUR

TRADE IN PROGRAM



CP-3002

TOG HIGH DENSITY COMPACTOR

TOG Industrial Features

- Reduce Hauling Costs - Compacting waste with a dual cylinder compactor will result in denser container loads and fewer trips to the landfill.
- Reduce Employee Labor - Use the compactor instead of your employees to break down large bulky refuse.
- Reduce employee pilferage with a security chute system.
- Meets or exceeds current ANSI Z245.2 Stationary Compactors Safety Standards.
- Heavy Industrial Construction for applications with daily container or trailer pulls.
- Large 58 x 52 clear top opening.

TOG Rental Program Benefits

- Engineering services for system designs that meet your individualized needs.
- American Manufacturer Electrical and Hydraulic Components - Specified for dependability, serviceability and nationwide availability.
- Outperforms and outlasts all other stationary
- Industry's leading warranty
 - Three Years - Ram and Frame Weldment
 - One Year - Electrical and Hydraulic Components Parts and Labor

Compactor Model	Mfr's. Rating (cu. yds.)	WASTEC Rating (cu. yds.)	Clear Top Opening (in.)		Chamber Length (in.)	Ram Stroke (in.)	Ram Penetration (in.)	Force Rating (Ram PSI abated forces lbs.)		Hydraulic Syst. Pressure PSI		Ram Face (in.)		Volume Displacement (cu. yds. per hr.)	Motor H.P.	Cycle Time (sec.)	Discharge Opening (in.)			Base Unit Weight (lbs.)
			Length	Width				Normal	Maximum	Normal	Max.	Width	Height				Width	Height	Frm Gnd	
CP-3002	3	2.02	52	58	56	74	18	50.5/84,800	60.6/101,800	1500	1800	60	28	139	20	52	60.75	67.25	16	9,300

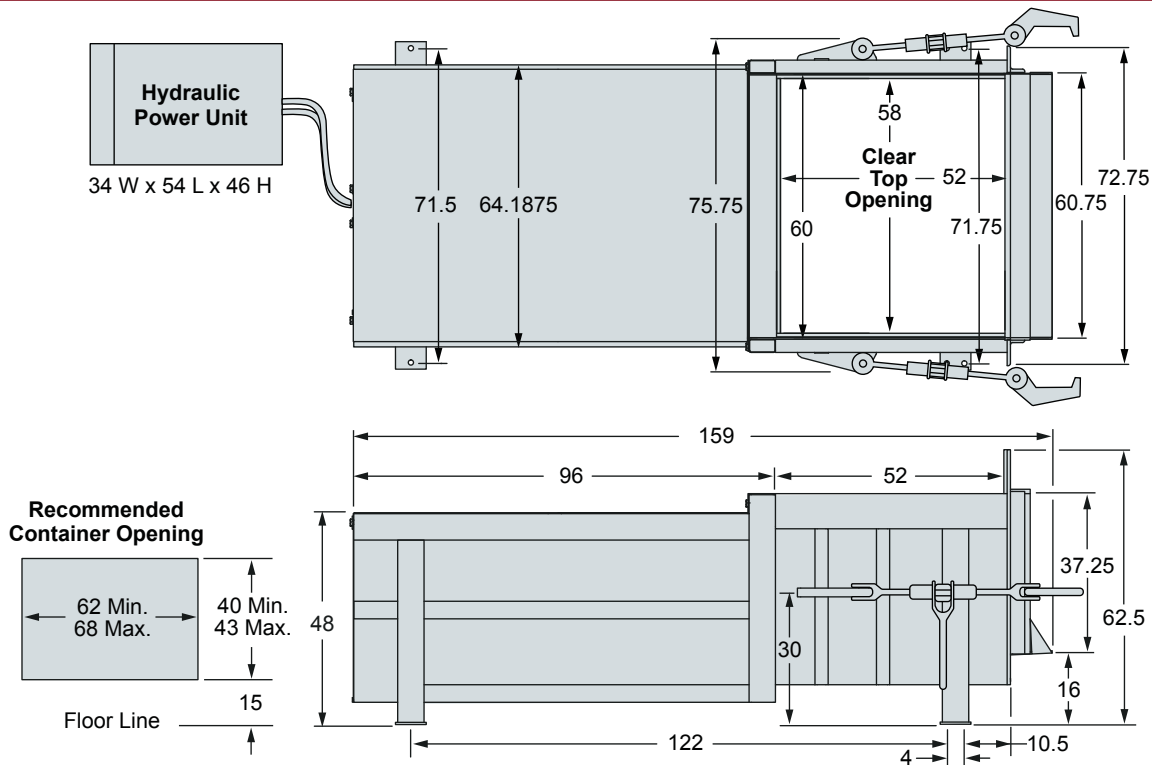

Standard Features

- Frame: Floor, Abrasion Resistant Steel Plate 1/2"
 - Floor Supports (4) S 3" x 5.7#
 - Structural I-beam (1) S 5" x 10#
 - Structural Tube (1) TS 6" x 4" x 3/8"
 - Side Plates 3/8"
 - Side Supports (2) TS 3" x 3" x 1/4"
 - Structural Tube (2) TS 6" x 3" x 1/4"
 - (1) TS 6" x 4" x 1/4"
 - (1) TS 8" x 3" x 1/4"
- Breaker Bar: T-1 Tool Steel 1-1/2" x 10" Vertical Bar
 - Weldment 1" x 4-1/2" Horizontal Bar
- Ram: Face Plate 3/4"
- Floor Plate 5/8"
- Side Plates 3/8"
- Top Plate 1/2"
- Top Supports (12) C 4" x 5.4#
- Guides Adjustable Nylatron Blocks
- Cylinders: (2) 6" Bore x 4.5" Rod x 74" Stroke
- Motor: 20 HP 208 or 230/460 Volt 3 Phase, ODP
- Pump: 30 GPM, Continuous Displacement Vane Type
- Reservoir: 75 Gallon
- Remote Power Unit
- Oil - Suitable for a Wide Temperature Range
- Oil Sight Gauge with Thermometer
- UL Listed Electrical Components
- Controls in Main Panel
 - Key Lock On/Off Switch
 - Pull-To-Start/Emergency Push-To-Stop Button
 - Keyed Jog Controls
 - Auto Multicycle
 - Automatic Safety Retract
 - Automatic/Manual Selector Switch
 - Ram Position Switch
 - Full/Jam Automatic Shut-off with Indicator
- Removable Rear Access Panels
- Ratchet Binder/Hooks: Heavy Duty Capacity

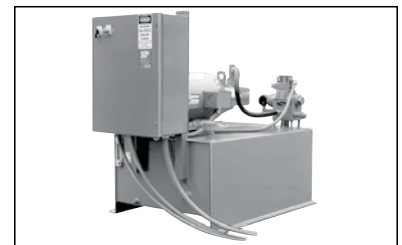

Remote Power Unit



Remote Control (Shown with an Optional Advance Full Load Indicator)

Optional Features

- Decks - 750#, 10,000# & Special Capacities
 - Safety Handrails
 - Safety Gate with Interlock
 - Side or Rear Load Hopper
 - Enclosed Doghouse Hopper w/Interlock Door(s)
 - Full Enclosure
 - Security Chute (Side or Rear)
 - Safety Interlock System
 - Deodorizer Spray System
 - UL Certified Panel and Controls
 - Unattended Electric Start System
 - Keyed Pinning/Boost Override System
 - Advance Full Load Indicator
 - TEFC Motor
 - Low/Hot Oil Indicator with Shut-off
 - Thermo Oil Heater
 - Power Unit Weather Cover or Shield
 - Container Guide
 - Through Wall Ratchet Kit
 - Cart Dumper System
- Ask Your Local Representative For Additional Options

CAUTION This Equipment Should Be Operated By Properly Trained Personnel. Improper Use, Misuse or Lack of Maintenance could cause injury to people and/or property. Photos used in this brochure are illustrative only. Due to its commitment to quality, TOG specifications are subject to change without notice to accommodate improvements to its equipment. Information contained within this literature is intended to be the most accurate available at the time of printing.

Distributed by:



17 Bank Street
P.O. Box 1240
Attleboro, MA 02703-0240

888-680-8644 Fax: 508-222-0757
email: sales@theokeefegroupinc.com
www.tog.us.com