



TOG EQUIPMENT LEASING, LLC

ASK ABOUT OUR

TRADE IN PROGRAM



CP-2101

TOG RECYCLING COMPACTOR

TOG Industrial Features

- Reduce Hauling Costs - Compacting waste into containers means fewer trips to the landfill.
- Reduce Employee Labor - Use the compactor instead of your employees to break down large bulky refuse.
- Reduce employee pilferage with a security chute system.
- Meets or exceeds current ANSI Z245.2 Safety Standards for Stationary Compactors.
- Dry Pack, Forward Sloping Floor Design - Liquid waste runs into the container reducing unsightly and offensive liquid discharge that can collect behind the ram and under the compactor.
- Heavy Commercial/Light Industrial Construction for applications with 1 to 2 container pulls per week.
- Large 57 x 46 clear top opening.

TOG Rental Plan

- Engineering services for system designs that meet your individualized needs.
- Choice of Maintenance Plans
- 100% Tax Deductible
- Biodegradable Oil Options
- 99% Run-Time Reliability
- Paper and Plastics Recycling
- Access to TOG Advisory Services
- Access to On-Going Service Management
- Optional Door-Seal Protection Plan
- Industry's leading warranty
 - Three Years - Ram and Frame Weldment
 - One Year - Electrical and Hydraulic Components Parts and Labor

Compactor Model	Mfr's. Rating (cu. yds.)	WASTEC Type Rating (cu. yds.)	Clear Top Opening (in.)		Chamber Length (in.)	Ram Stroke (in.)	Ram Penetration (in.)	Force Rating (Ram PSI at stated forces lbs.)		Hydraulic Syst. Pressure PSI		Ram Face (in.)		Volume Displacement (cu. yds. per hr.)	Motor H.P.	Cycle Time (sec.)	Discharge Opening (in.)			Base Unit Weight (lbs.)
			Length	Width				Normal	Maximum	Normal	Max.	Width	Height				Frm Gnd			
CP2101	2	1.61	46.5	57.6	47.5	60	12.5	26.8/42,200	29.9/47,100	2150	2400	59.5	26.5	116	10	50	30.68	33.5	15.5	5,100
CP2101-HD	2	1.61	46.5	57.6	47.5	60	12.5	32.2/50,900	35.6/56,500	1800	2000	59.5	26.5	121	10	48	30.68	33.5	15.5	5,300

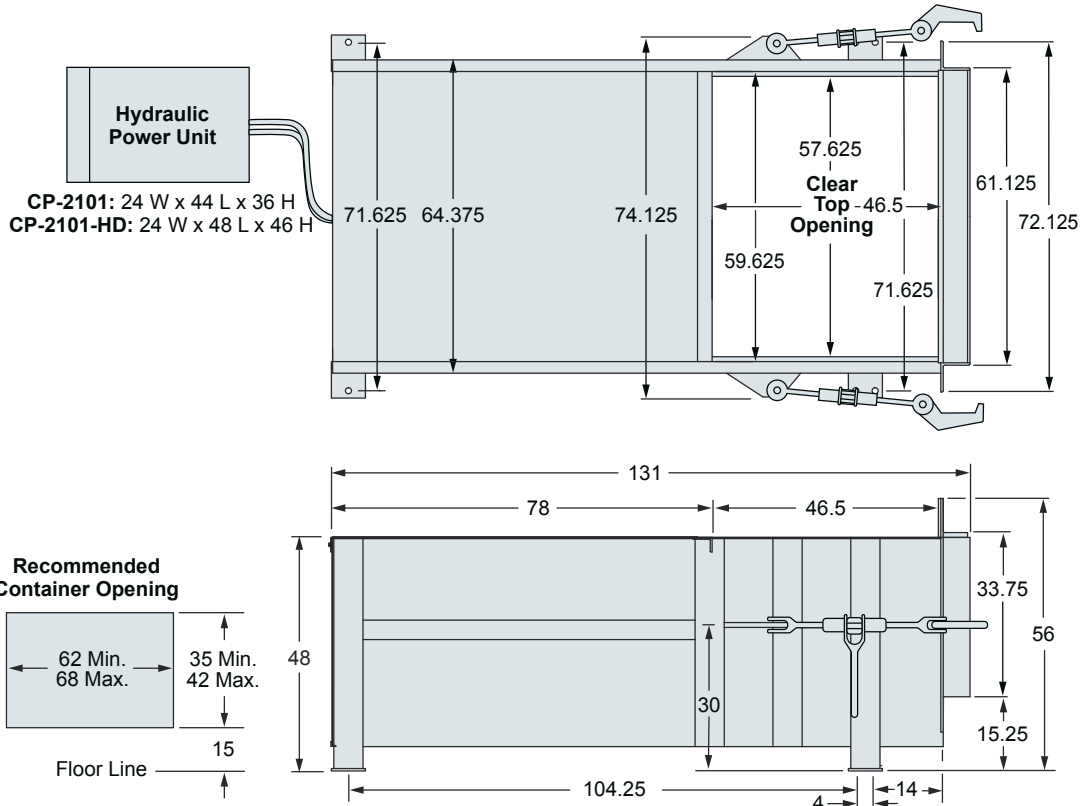

Standard Features

- Frame: Floor 3/8"
 Floor Supports (5) C3 x 4.1#
 (1) C6 x 13#
 Side Plates 3/16"
 Side Supports (3) C6 x 8.2#
- Breaker Bar: L 8" x 6" x 1"
- Ram: Face Plate 3/4"
 Floor Plate 5/8"
 Side Plates 3/16"
 Top Plate 1/4"
 Top Supports (7) C3 x 4.1#
 Guides Adjustable Nylatron Blocks
- Cylinder: CP-2101 - (1) 5" B x 3" R x 60" S
 CP-2101-HD - (1) 6" B x 3" R x 60" S
- Motor: 10 HP 208/230/460 V 3PH ODP
- Pump: CP-2101 - 10 GPM Continuous Displacement
 CP-2101-HD - 16 GPM Continuous Displacement

- Reservoir: CP-2101 - 25 Gallons
 CP-2101-HD - 40 Gallons
- Remote Power Unit
- Oil - Suitable for a Wide Temperature Range
- Oil Sight Gauge with Thermometer
- UL Listed Electrical Components
- Controls in Main Panel
 Key Lock On/Off Switch
 Push/Pull Emergency Stop/Start Button
 Auto Multicycle
 Automatic Safety Retract
 Automatic/Manual Selector Switch
 Ram Position Switch
 Full/Jam Automatic Shut-off with Indicator
- Removable Access Panels
- Ratchet Binder/Hooks: Heavy Duty Capacity



Remote Power Unit

Optional Features

- Decks - 750#, 10,000# & Special Capacities
 - Safety Handrails & Toerails
 - Safety Gate with Interlock
 - Side or Rear Load Hopper
 - Enclosed Doghouse Hopper with Door(s)
 - Side or Rear Load Security Chute
 - Full Enclosure
 - Safety Switch Interlock System
 - Deodorizer Spray System
 - UL Certified Panel and Controls
 - Unattended Electric Start System
 - Keyed Pinning/Boost Override System
 - Advance Full Load Indicator
 - TEFC Motor
 - Low/Hot Oil Indicator with Shut-off
 - Thermo Oil Heater
 - Power Unit Weather Shield or Cover
 - Container Guides
 - Through Wall Ratchet Kit
- Ask Your Local Dealer For Additional Options

!CAUTION! This Equipment Should Be Operated By Properly Trained Personnel. Improper Use, Misuse or Lack of Maintenance could cause injury to people and/or property. Photos used in this brochure are illustrative only. Due to its commitment to quality, TOG specifications are subject to change without notice to accommodate improvements to its equipment. Information contained within this literature is intended to be the most accurate available at the time of printing.

Distributed by:



17 Bank Street
 P.O. Box 1240
 Attleboro, MA 02703-0240

888-680-8644 Fax: 508-222-0757
 email: sales@theokeefegroupinc.com
 www.tog.us.com